

# USE AND INSTALLATION OF ALL POLAR CABINET COOLERS



6320 Wiehe Road, Cincinnati, Ohio 45237

Phone: 1-513-631-0660 / [www.airtx.com](http://www.airtx.com)

## 1. COMPRESSED AIR SUPPLY

Air supplies are plagued with condensed water vapor and droplets in the air lines. This condensation leads to rust and dirt in the air lines. Also, some compressors will allow oil or oil vapor to enter the air line. Small orifices in the AiRTX Cabinet Cooler may become clogged with rust, dirt, and water droplets.

A 5-micron filter will separate 99% of the foreign material from the air supply, allowing virtually maintenance free operation. The use of an oil filter with an effective filtration of 0.01 ppm will remove the oil droplets for an even cleaner air supply.

**Model 90175** automatic drain air filter can be used with all Coolers to remove foreign material and water droplets. This filter is standard with the thermostatic Cabinet Cooler models.

**Model 91175** oil filter can be used with all models.

Keep in mind that the current line or air hose might contain dirt or oil and should be blown out before installation. Also, pipe thread sealant or tape must be carefully applied to avoid clogging product orifices.

## 2. COMPRESSED AIR SUPPLY LINE SIZE

To obtain maximum performance from the AiRTX products, adequate amounts of air pressure and volume must be present.

Line pressure of 70-90 psi can be available without a sufficient volume (cfm) of air. To ensure that both pressure and volume are available to efficiently operate the AiRTX Coolers, a line size of 1/4" pipe or 1/2" hose should be used for applications up to 10 ft. from the compressed air main header. Use 3/8" pipe or 3/4" hose up to 20 ft. and 1/2" pipe or 1" hose up to 50 ft. from the header.

## 3. USE AND INSTALLATION OF POLAR CABINET COOLER:

The last 2-digits of the Cabinet Cooler models indicate the cfm usage at 100 psi. The generators determine the volume of air through the Cabinet Cooler. These generators are rated 8, 15, 25, and 35 cfm at 80 psi. To ensure that your air compressor can generate these volumes, the (horse power) of the compressor can be multiplied by four to determine the cfm capacity. A multiplier of 5 can be used on newer compressors over 30 horsepower.

The standard model Cabinet Cooler 70025 is equipped with a 25 cfm generator and 8' of vinyl ducting to route the cold air inside the cabinet.

This will provide 1800 BTU of cooling. This is sufficient to cool a cabinet that is 6 ft. x 6 ft. x 2 ft. from a 140°F maximum inside temperature to 90°F., provided 80 psi air is available going into the AiRTX Cabinet Cooler.

When 80 psi is not available, the potential BTUs of cooling must be reduced by 25% at 60 psi, or 50% at 40 psi. The Model 70008 will cool cabinets of 4' x 3' x 1' or smaller. All thermostat models are very useful at controlling compressed air usage as it only operates when internal cabinet temperature exceeds 90°F.

Changing the temperature setting of the thermostat is as easy as adjusting the thumb wheel to the desired temperature.

Furthermore, 90° +/- 5° is the optimal setting for effective and efficient compressed air usage.



Each thermostatic model includes the Cabinet Cooler and following components: Auto Drain Filter, Ducting Kit, Thermostat and Solenoid Valve.

## 4. INSTALLATION AND MOUNTING FOR ALL CABINET COOLER MODELS

The drawing suggests a way the Cabinet Cooler can be mounted regardless of which Model you ordered. The Cabinet Cooler operates the same in any place, so it can be mounted perpendicular to the side or back of the cabinet. **It can also be mounted using a 90° electrical elbow Model 70000-11.** The drawing shows the thermostat, solenoid, and automatic drain air filter if you ordered one of the thermostatic models. The Cabinet Cooler requires a standard 1" electrical knockout for installation and a 7/32" hole for electrical wires for the thermostat.

### INSTALLATION THERMOSTATIC CABINET COOLER SYSTEM

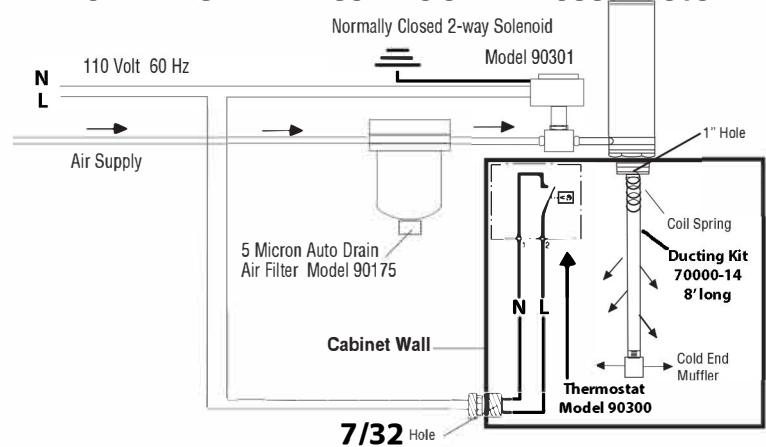

### ELBOW MODEL 70000-11

Also Available

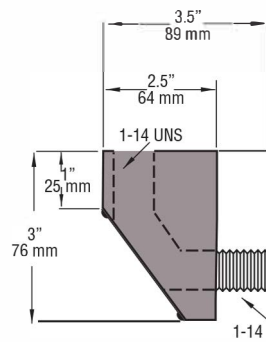

The Mounting Elbow is available for tight spaces and upright positioning.

### INSTALLATION MOUNTING ELBOW MODEL 70000-11

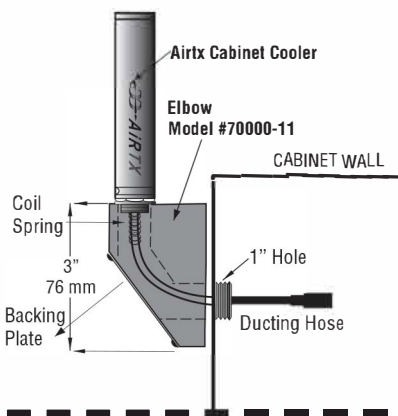

The Airtx Cabinet Cooler can be mounted in any place and work just as efficiently.

The Model 70000-11 is attached to the Cabinet wall through a 1" hole. O rings seal the mounting Elbow maintaining the integrity of a NEMA 4 or 12 Cabinet.

## 5. OPERATION OF COOLING

The AiRTX Cabinet Cooler is factory set to deliver the maximum cooling needed to maintain a desired temperature inside your control panel.

At 80 psi, 17.5 cfm (70% of 25 cfm) of cold air will exit from the Model 70025 Cabinet Cooler into the panel, providing 1800 BTU of cooling.

At 80 psi, Model 70015 will deliver 10.5 cfm of cold air inside the cooler, providing 1100 BTU's of cooling. Model 70035 delivers 2800 BTU's of cooling based on 70% of 35 cfm or 24.5 cfm of cold air.

The bladder valve, located at the base of Cabinet Cooler, will automatically release hot air from the cabinet, maintaining a positive pressure inside the cabinet. The automatic release of air through the bladder valve enables you to close off open conduit entrances, louvers and air leaks. A sealed cabinet is also more efficient, as the cold air enters only the cabinet and doesn't escape to the atmosphere, generating increased compressed air usage. A sealed cabinet also eliminates potential condensation from forming on the components. The bladder valve keeps the integrity of a Nema 4, 4x, or 12 cabinet. The construction allows for wash-down situations. "UL Listing is for use on a flat surface of a type 1 enclosure".

## 6. CONTINUOUS RUNNING OPERATION;

For Cabinet Coolers operating continuously, those without thermostats, condensation may form on the outside of the Cabinet. If this occurs, regulate the compressed air to a lower setting (50-60 psi) This will drop the inlet compressed air temperature to 30°F instead of 50°F at 80 psi and reduce the water droplets on the outside of the cabinet while still maintaining proper inside cooling. The 8' of vinyl ducting and internal muffler should always be installed to properly distribute cooling to all internal components.

## 7. CLEANING AND MAINTENANCE

The AiRTX Cabinet Cooler has no moving parts. Clean, compressed air moving through the tube will not cause wear on the parts and will provide you with the same reliable service for an indefinite period of time.

Occasionally, dirt, water, or oil may enter the tube from the compressed air supply and hinder the performance. If this happens, simply take the unit apart, clean the parts, and reassemble, tightly replacing the cold end cap to properly seat the generator.

## 8. DUCTING

The 8ft. of vinyl ducting connects to the cold end of the Cabinet Cooler inside the electrical cabinet. The ducting allows more efficient use of the cold air by routing the cold air to the hottest spot. By cutting a hole in the tube at the hot spot, the cold air cools more effectively, restricting the high temperature increase of the particular hot control.

The muffler end of the ducting should be placed toward the bottom of the cabinet. As the cold air exits from the muffler, it rises as it heats and provides more even cooling throughout the cabinet.

### INSTALLING THE DUCTING KIT INCREASES COLD AIR DISTRIBUTION AND EFFICIENCY OF THE CABINET COOLER (MUST BE INSTALLED)

1. Push the open end of the clear vinyl ducting over the extension tube of the Cabinet Cooler. There is no need for a clamp as the tubing will remain in place.
2. Using a knife, cut small holes in the tubing to allow cold air to escape along the 8 feet length of the tubing. Let the cold air blow directly on hot relays or motor controls to keep them from getting overheated.
3. Use the three enclosed clips to hold the tubing in place throughout the cabinet.
4. Let the excess tubing with the muffler attached fall to the bottom of the cabinet. As the cold air escapes and picks up heat from the electronics, the hotter air will rise and be exhausted through the bladder valve on the Cabinet Cooler and exit outside the Cabinet.
5. While the ducting is very important to carry air throughout the cabinet, restricting the cold air flow through the ducting decreases the efficiency and cooling of the controls. The enclosed coil spring can be placed on the outside of the ducting tube in areas to prevent the tubing being crimped or bent enough to restrain the cold air flow.

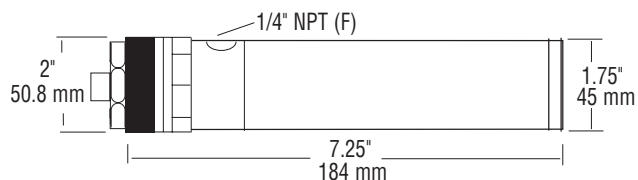

**Aluminum Model 75008, 15, 25, 35  
Stainless Steel Model 70015, 25, 35**

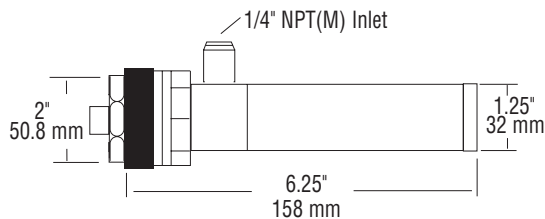

**Stainless Steel Model 70008**

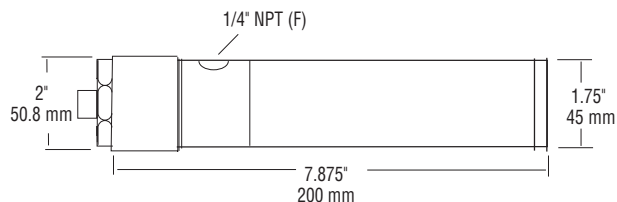

**Stainless Steel Model Model 700015x, 25x, 35x**

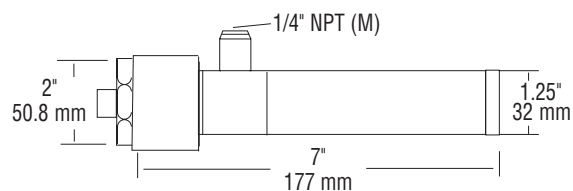

**Stainless Steel Model 70008x**

Also Available

**AiRTX Complete System  
Easy Mount Turnkey  
Cabinet Cooling Enclosure for  
hazardous environments**

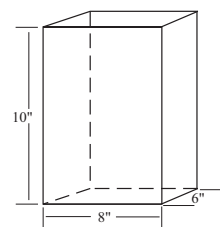
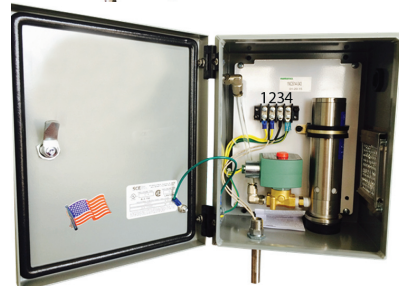
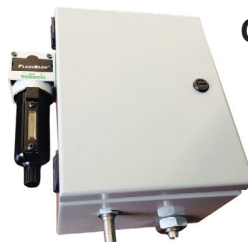

Model 70308CC 600 BTU/H  
Model 70315CC 1100 BTU/H  
Model 70325CC 1800 BTU/H  
Model 70335CC 2800 BTU/H

Part #	Description
70000-14	8' vinyl ducting with muffler
90300	Thermostat preset 90°F (32°C)
90175	1/4" 5 micron auto drain filter
90301	1/4" normally closed 2-way solenoid
70000-11	Mounting Elbow

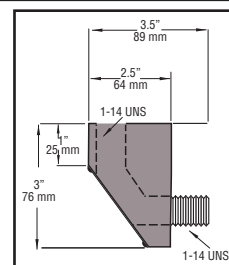

Mounting Elbow