

USE AND INSTALLATION OF THE AiRTX VORTEX TUBES (Aluminum/Stainless)



6320 Wiehe Road, Cincinnati, Ohio 45237
Phone: 1-513-631-0660 / www.airtx.com

1. COMPRESSED AIR SUPPLY

Air supplies are plagued with condensed water vapor and droplets in the air lines. This condensation leads to rust and dirt in the air lines. Also, some compressors will allow oil or oil vapor to enter the air line.

Small openings in the AiRTX Vortex Tubes, may become clogged with rust, dirt, and water droplets. A 5-micron automatic drain filter, **Model 90175** will separate 99% of the foreign material and water from the air supply, allowing virtually maintenance free operation. The use of an oil filter, **Model 91175** with an effective filtration of 0.01 ppm will remove the oil droplets for an even cleaner air supply.

Keep in mind that the current line or air hose might contain dirt or oil and should be blown out before installation. Also, pipe thread sealant or tape must be carefully applied to avoid clogging product orifices.

When the temperature of the air inside the Vortex Tube, reaches 32°F (0°C), the water vapor in the air will start to freeze. If this poses a problem with the ice clogging the orifices of the generator inside the tube, an air dryer may be used to lower the dew point to keep out the water vapor. A desiccant dryer rated at -35°F will produce a dew point low enough to eliminate the water vapor freezing in the orifices of the generator. You may also reduce the air pressure or install a larger generator to relieve icing.

2. COMPRESSED AIR SUPPLY LINE SIZE

To obtain maximum performance from the AiRTX products, measurements of pressure (psi) and volume (cfm) of air must be obtained. Line pressure of 70-90 psi can be present without a sufficient volume (cfm) of air. To ensure that both pressure and volume are present to efficiently operate the AiRTX products, a line size of 1/4" pipe or 1/2" hose should be used for applications up to 10 ft. from the main compressed air header. Use 3/8" pipe or 3/4" hose up to 20 ft. and 1/2" pipe or 1" hose up to 50 ft. from the header to compensate for line pressure at greater distances from the main air supply.

3. GENERATORS - VOLUME OF AIR.

The AiRTX generators determine the volume of air through the Vortex Tube. These generators are rated, 10, 15, 25, and 35 cfm at 80 psi. To ensure that your air compressor can generate these volumes, the (horse power) of the compressor can be multiplied by four to determine the cfm capacity. A multiple of 5 can be used on newer compressors over 30 horse power. There are 2 types of generators for each of the 4 cfm ranges. The H is for maximum BTU cooling. This occurs when the cold fraction is above 50%. For low flow but very cold temperature use the L generator for a cold fraction below 50%. The generators are color coded for the different cfm ratings and for maximum cooling or low temperature.

Changing the Generators-to change the generator and thus the volume of air, simply remove the cold cap using a 1" wrench. Pull out the o-ring and generator by hand and replace it with the desired generator. Replace the o-ring on the new generator and tighten the cold cap.

Cold Fraction is the percentage of the incoming air, from the compressed air supply, exiting from the cold end. The AiRTX generator determines the amount of air or consumed cfm. By turning the black delrin hot end valve one turn ccw, from the closed position, an 80% cold fraction is achieved. The smaller the percentage, the colder the air. 4 1/2 turns ccw from the closed position produces maximum cold temperatures at a 10% cold fraction. For example, using a 10 cfm generator with a cold fraction of 60% results in 6 cfm of air out the cold end and 4 cfm out the hot end. There has to be some air flowing from both ends of the vortex tube simultaneously to produce heating and cooling.

The Application Development Kit Model 20400 contains the large Stainless Steel Vortex Tube, 8 generators, a cold end muffler, air filter, and 12 inches of Flex Line to direct the cold air. Use filtered oil-free air not exceeding 250 PSIG.

4. DUCTING THE AIR

The air exiting from the cold end or hot end is just above atmosphere pressure. It is important to use a tube, when ducting the air, that is at least as large as the outlet of the AiRTX Vortex Tube. Also, since outlet pressure is low, restricting the ducted air through a small nozzle or into a container will create back pressure and cause poor cooling or heating performance.

Several ducting systems are available from AiRTX using Snap Flex Line. You can customize these snap together flexible units to fit the length and direction you need for your application.

5. CLEANING AND MAINTENANCE

The AiRTX Vortex Tube has no moving parts. Clean compressed air moving through the tube will not cause wear on the parts and will provide you with the same reliable service for an indefinite period of time.

Occasionally, dirt, water, or oil may enter the tube from the compressed air supply and hinder the performance. When this happens, simply take the unit apart, clean the parts, and reassemble, tightly replacing the cold end cap to properly seat the generator.

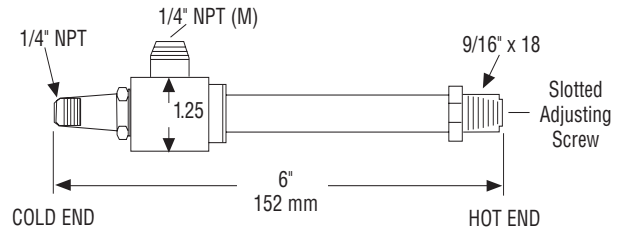

▲ Vortex Tube Model 20008 SS

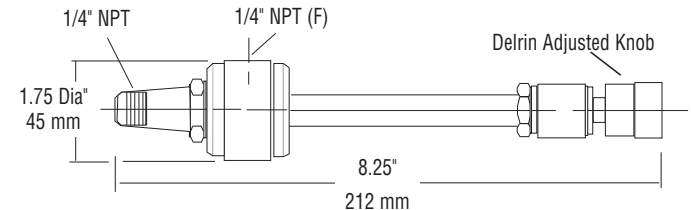

▲ Vortex Tubes Models 20010-20035 SS

*Available with 1/4" BSP

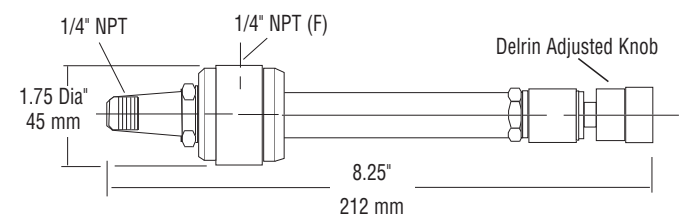

▲ Vortex Tubes Models 25010-25035 Aluminum

*Available with 1/4" BSP

Color Coding of Vortex Tube Generators

CFM	10	15	25	35
	yellow	red	blue	orange
Max Cold	green	white	gray	taupe

The last 2-digits of the part number indicate the generator cfm i.e. Model 20015 is a 15 cfm vortex tube.

ASK ABOUT

www.airtx.com

STAINLESS STEEL AIR GUNS



Model 60051

ADVANTAGES- PORTABLE AIR GUN

- No liquids, ozone-depleting chemicals or residue
- Increase feeds, speeds and quality
- Eliminates liquid coolant cost, contamination, skin irritation, mess on walls/floors/machines
- Finishes the job with a clean, dry part
- Improves tool life, production rates, finish and tolerances
- Eliminates microcracking and burning
- Reduces wheel loading and dressing

*Sub-Freezing Air Dry Machining and Spot Cooling
Industrial Processes- Reliable, Non-Toxic,
Non Polluting, No Residu, Low Cost.*

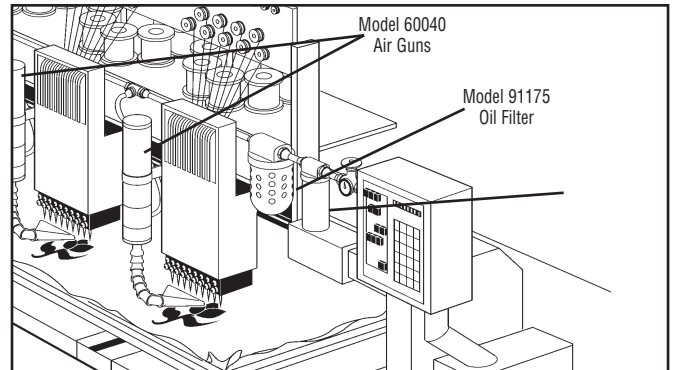

Textiles — Sewing/Embroidering

In production sewing or embroidering, the Model 60040 Air Gun eliminates needle heat build-up, which can cause thread burn-through and stoppages.

ASK ABOUT

www.airtx.com

STAINLESS STEEL/ 316-SS POLAR CONTROL COOLERS



Model 70008x
Model 70015x



(Also available in Aluminum)



ADVANTAGES- POLAR CABINET COOLER

- Higher BTU per CFM
- Greater cooling with the same air usage
- Wide range of Cooling (600-5600 BTUH)
- No vibration to affect CCTV cameras
- Thermostatically controlled units available
- Compact for cramped factory areas
- No maintenance, no moving parts
- Requires no electricity • No RF/EMI interference
- No fans or filters • Muffled for quiet operation
- **Maintain NEMA 4, NEMA 4x, and NEMA12 integrity**

Use Them Anywhere! *Keep Factory-Floor Controls On-line in the worst possible conditions with up to 5600BTU/H of Cooling. Compressed-Air-Operated Stainless Cabinet Coolers for Hazardous Environments.*

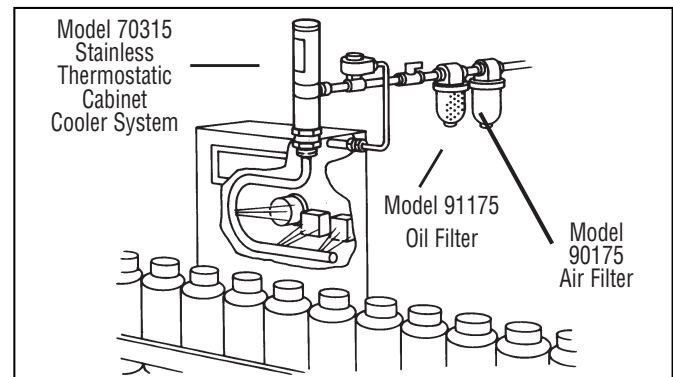

Bottling Plant

AiRTX Cabinet Cooling Systems are Stainless Steel, so wash-down of these leak testing and production controls in a bottling operation is easy. NEMA cabinets can be secured without concern for heat build-up.

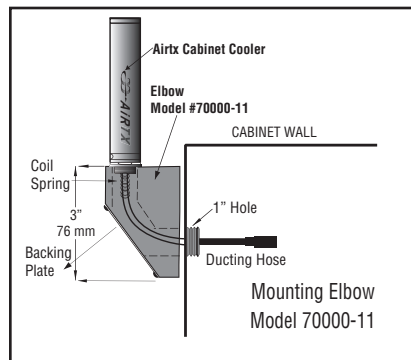

Call 513-631-0660

Easy Mount Turnkey Cabinet Enclosure